

**120<sub>L</sub>**  
Capacity

**48<sub>Kg</sub>**  
Nominal load

**200<sub>mm</sub>**  
Wheels diameter



### FEATURES

The body and lid are injection moulded in solid coloured high-density polyethylene.

Manufactured using environmentally-friendly recyclable materials.

No heavy metals in the pigments.

Ideal for different types of waste collection: paper and cardboard, glass, packaging, organic matter, etc. ...

Available in a wide range of colours..

DIN or AFNOR standard lifting systems.

Customisation of lid with thermal transfer graphic, area: 230 x 45 mm.

Customisation of lid with an embossed logo, area: 340 x 220 mm.

Customisation of body with silk screen or thermal transfer graphic, area: 280 x 290 mm.

CE Marking with sound power level indicated in accordance with European Directive 2000/14/EC. 80,4 db.

UN certificate for the transportation of hazardous goods.

Product Approval Certificate awarded by TÜV SÜD Product Service GmbH in accordance with European Standard EN 840: 2012 and specifications of RAL-GZ 951/1

### STANDARDS

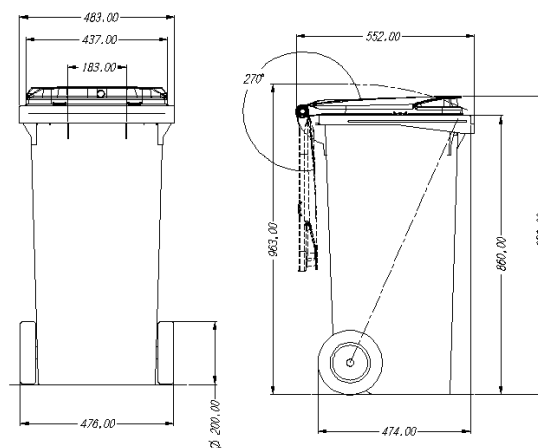

These dimensions are subject to the tolerances given in EN 840-1:2012.

### ATTRIBUTES



QUALITY



ERGONOMICS



FUNCTIONALITY

### ACCESSORIES

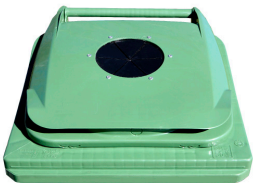

GLASS APERTURE



PLASTIC APERTURE



PAPER APERTURE



SIDE HANDLE



CUSTOMISATION



CUSTOMISATION



PEDAL



AVAILABLE IN A WIDE RANGE OF COLOURS

### EQUIPMENT

200 mm diameter wheels.

Openings with sizes and features specially designed to accommodate each type of waste, making them easy to use.

Integrated sound-proofing system in the lid.

Recess for electronic chips.

Can be equipped with a range of accessories providing real solutions to every requirement: pedal-operated lid opening, reflective strips, lock, side handle.

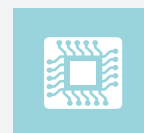

Electronic Chip

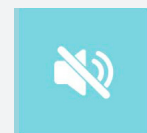

Sound-proofing

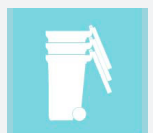

Easy to stack



Lock



Customisation

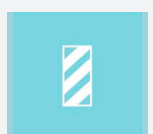

Reflective strips