



FEATURES

The body and lid are injection moulded in solid coloured high-density polyethylene.

Manufactured using environmentally-friendly recyclable materials.

No heavy metals in the pigments.

Specifically designed for domestic compost production based on organic household, kitchen or garden waste.

Customisation of lid with thermal transfer graphic, area: 230 x 45 mm.

Customisation of lid with an embossed logo, area: 340 x 220 mm.

Customisation of body with silk screen or thermal transfer graphic, area: 280 x 290 mm.

Air vents and internal base manufactured in polyethylene.

CE Marking with sound power level indicated in accordance with European Directive 2000/14/EC.

MODEL	1	3	4	5	6
C90	480 mm	550 mm	855 mm	791 mm	475 mm
C120	480 mm	550 mm	968 mm	713 mm	475 mm
C140	480 mm	550 mm	1074 mm	1010 mm	475 mm
C240	580 mm	728 mm	1071 mm	995 mm	570 mm

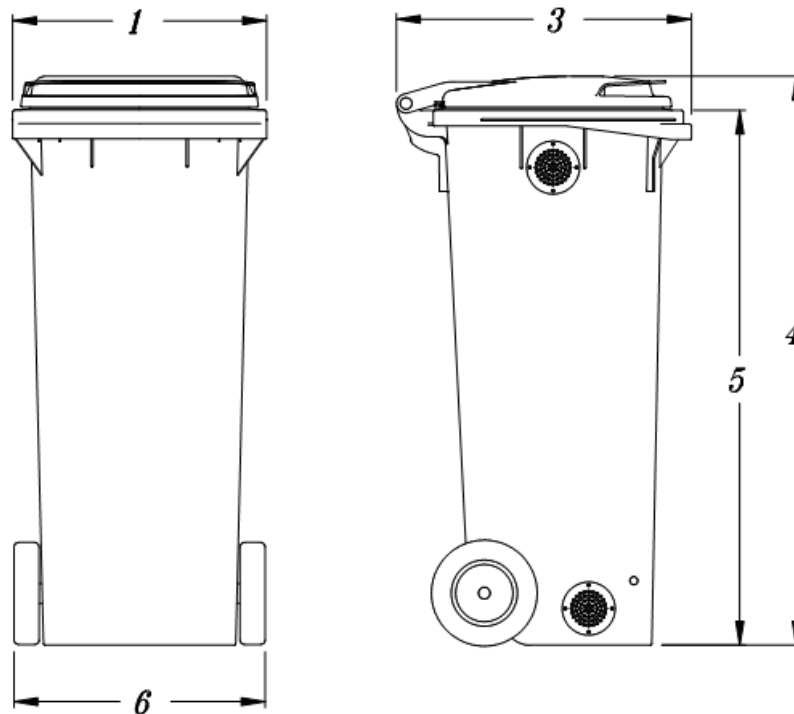

ATTRIBUTES



VERSATILITY



ERGONOMICS

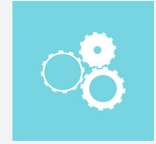

FUNCTIONALITY



AIR VENTS



AIR VENTS

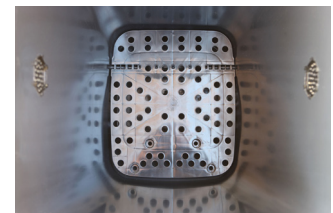

INTERNAL BASE



CUSTOMISATION



CUSTOMISATION



HANDLES

EQUIPMENT

200 mm diameter wheels.

Integrated sound-proofing system in the lid.

Recess for electronic chips.

Upper and lower air vents and internal base manufactured in polyethylene.

DIN or AFNOR standard lifting system.

STANDARDS



Electronic Chip

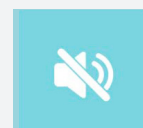

Soundproof



Domestic compost

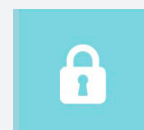

Lock



Customisation



Resistant to atmospheric conditions